



SUPERCAPRI

Gelato and pastry display cabinet



your visible value



SUPERCAPRI

Gelato and pastry display cabinet



your visible value

SUPERCAPRI

SUPERCAPRI is the synthesis of an essential design and high-level technical features. It is equipped with glass side windows with heated chamber and heated stratified front glass that can be opened.

Three different ventilations enhance the technical performance:

PLUS: single evaporator with double front air out flow.

PLUS 1: double evaporator with single air out rear flow.

PLUS 2: double evaporator with double air out rear flow.







PLUS



PLUS 1



PLUS 2

Three types of ventilation.
Discover them on page 12.

Tre tipologie di ventilazione
Scoprirete a pagina 12.

Adjustable deflectors for
lower energy consumption
(Plus1 - Plus2 only)

Deflettori regolabili per un
minore consumo energetico
(solo Plus1 e Plus2)

Excellent gelato
visibility.

Eccellente visibilità
del gelato.



SUPERCAPRI

IT

SUPERCAPRI è la sintesi di un design essenziale e caratteristiche tecniche di alto livello. Dotata di vetri laterali in vetro camera riscaldato e vetro frontale stratificato riscaldato ribaltabile. Tre differenti ventilazioni esaltano le performance tecniche:

- **PLUS** singolo evaporatore a doppia mandata d'aria a flusso anteriore.
- **PLUS 1** doppio evaporatore a singola mandata d'aria a flusso posteriore.
- **PLUS 2** con doppio evaporatore a doppia mandata d'aria e flusso posteriore.

DE

SUPERCAPRI ist die Synthese zwischen essentielles Designs und hochwertige technische Eigenschaften. Ausgestattet mit beheizte Doppelflas Seitenscheiben und beheizte kippbare geschichtete Frontscheibe. Drei verschiedene Lüftungen heben die technische Leistung hervor:

- **PLUS** einzelner Verdampfer mit doppelter Zuluft mit Luftstrom vorne.
- **PLUS 1** doppelter Verdampfer mit einzelner Zuluft mit Luftstrom hinten.
- **PLUS 2** mit doppeltem Verdampfer mit doppelter Zuluft mit Luftstrom hinten.

FR

SUPERCAPRI est la synthèse d'un design essentiel dans ces caractéristiques techniques de haut niveau. Équipé de vitres latérales double vitrage et d'un verre frontal feuilleté chauffant et rabattable. Trois ventilations différentes exaltent les performances techniques:

- **PLUS**: un seul évaporateur à double refoulement d'air à flux antérieur.
- **PLUS 1**: deux évaporateurs à simple refoulement d'air à flux postérieur.
- **PLUS 2**: deux évaporateurs à double refoulement d'air et flux postérieur.

ES

SUPERCAPRI es la síntesis de un diseño esencial y características técnicas de alto nivel. Dotada de cristales laterales de vidrio cámara calentado y cristal frontal estratificado calentado que se puede abrir. Tres distintas ventilaciones exaltan los rendimientos técnicos:

- **PLUS** evaporador individual de doble salida de aire con flujo frontal.
- **PLUS 1** evaporador doble de salida individual de aire con flujo posterior.
- **PLUS 2** con doble evaporador de dos salidas de aire y flujo posterior.

GELATO

SUPERCAPRI



Gelato 220

*Cioccolato
Stracciatella
Crema
Fiordilatte
Nocciola
Caffè
Pistacchio
Bacio
Yogurt
Gianduja
Vaniglia*

*Torrone
Nutella
Pinolata
Zuppa inglese
Cookies
Tiramisù
Liquirizia*

*Fragola
Pesca
Limone
Melone
Anguria
Mango
Cocco
Banana
Mela
Ananas
Kiwi*



Gelato 220

SUPERCAPRI

H 117 • 135

P 111

L 120 • 170 • 220 • 120+50 • 170+50 • AE45

Gelato

Installation

- Plug-in
- Remote (optional)

Configuration

- Canalized (optional)
- Dual Temperature (optional)

Temperature

-20/+2 °C

Refrigerant

R404A

Refrigeration

- Ventilated
- Plus
- Plus 1 (optional)
- Plus 2 (optional)

Compressor

Hermetic

Defrost

Reverse cycle

Climatic class

- 7 - Plus
- 4 - Plus 1 / Plus 2

Upper glass

Heated stratified glass with switch

Front glass

Heated stratified glass

Side glasses

Heated double glasses

Opening system

Front glass tilted manually

Rear closing system

- Plexiglass Sliding doors
- Self rolling curtain

Work top

Solid surface White

Lightning

Led 5700 K°

Equipment handling

Swivel casters with brake and height adjustable feet

Installazione

- Plug-in
- Remoto (optional)

Configurazione

- Canalizzabile (optional)
- Dual Temperature (optional)

Temperatura

-20/+2 °C

Refrigerante

R404A

Refrigerazione

- Ventilata
- Plus
- Plus 1 (optional)
- Plus 2 (optional)

Compressore

Ermetico

Sbrinamento

Inversione di ciclo

Classe Climatica

- 7 - Plus
- 4 - Plus 1 / Plus 2

Vetro superiore

Stratificato riscaldato (disattivabile)

Vetro frontale

Stratificato riscaldato

Vetri laterali

Doppi (Camera) riscaldati

Apertura anteriore

Ribaltabile verso il basso

Chiusura posteriore

- Scorrevoli in Plexiglass
- Tenda manuale autoavvolgente

Piano di servizio

Superficie solida bianca

Illuminazione

Led 5700 K°

Movimentazione

Ruote pivotanti con freno e piedini regolabili in altezza



Front glass
Heated stratified glass

Vetro frontale
Stratificato riscaldato

Upper glass
Heated stratified glass
with switch

Vetro superiore
Stratificato riscaldato
(disattivabile)

Side glasses
Heated double glasses

Vetri laterali
Doppi (Camera) riscaldati



Dual Temperature

Designed with maximum flexibility to allow seasonal product display management. The Dual Temperature function (optional) allows the display cabinet to change simply, the operating temperature for Ice Cream and Pastry Products. This allows one cabinet to offer seasonal flexibility without increasing floor space.

Massima flessibilità e perfetta gestione dei cicli stagionali. La funzione Dual Temperature (optional) permette alla vetrina di passare con estrema semplicità da Gelateria a Pasticceria, e viceversa, permettendovi di avere un locale multifunzionale con un unico prodotto: possibilità di variare stagionalmente l'offerta e il layout del vostro spazio.

Plus.

Total control of cold performances



Single evaporator with double front air out flow.

Singolo evaporatore con doppia mandata d'aria a flusso anteriore.

Évaporateur simple avec
refoulement de l'air à flux
avant double.

Einzelner Verdampfer
mit doppelter Luftzuleitung
mit vorderem Luftstrom.

Evaporador sencillo con
doble línea de impulsión de
aire de flujo anterior.

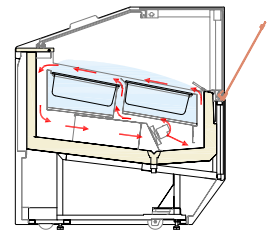

Double evaporator with single air out rear flow.

Doppio evaporatore con singola mandata d'aria a flusso posteriore.

Évaporateur double avec
refoulement de l'air à flux
arrière simple.

Doppelter Verdampfer
mit einzelner Luftzuleitung
mit hinterem Luftstrom.

Evaporador doble con una
sola línea de impulsión de
aire de flujo posterior.

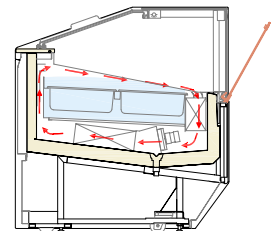

Double evaporator with double air out rear flow.

Doppio evaporatore con doppia mandata d'aria a flusso posteriore.

Évaporateur double avec
refoulement de l'air à flux
arrière double.

Doppelter Verdampfer
mit doppelter Luftzuleitung
mit hinterem Luftstrom.

Evaporador doble con
doble línea de impulsión de
aire de flujo posterior.

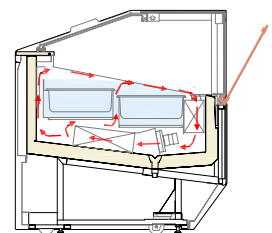





PLUS



PLUS 1



PLUS 2





Gelato Style	Gelato	•	•	•
	"High" Gelato Gelato "Alto"	-	• recommended / consigliato	•
	Ice cream sticks Stecchi	•	•	•
	Single portions Monoporzioni	•	•	•
	Frozen pastry Pasticceria fredda	•	•	•
Performance	Evaporators Evaporatori	1	2	2
	Air outlet Mandata d'aria	2	1	2
	Inclination of the display Inclinazione del piano espositivo	11°	3°	0°
	4 - Climate Class / Classe climatica 30 °C / 55 %RH		•	•
	7 - Climate Class / Classe climatica 35 °C / 75 %RH	•		
	Air out deflectors Deflettori uscita aria	Fixed Fissi	Adjustable Regolabili	Adjustable Regolabili
Setup Allestimento	Container / Vaschetta 5 Lt. 360x165x120h	•	•	•
	Container / Vaschetta 7 Lt. 360x165x150h	-	-	-
	Container / Vaschetta 5 Lt. 360x250x80h	•	•	•
	Container / Vaschetta 10 Lt. 360x250x120h	-	-	-
	Container / Vaschetta 12 Lt. 360x250x150h	-	-	-
	Container / Vaschetta 5 Lt. 360x165x120h TRAPEZOIDALE	•	•	•
	Ice cream stick container / Vaschetta stecchi 360x250x43h	•	•	•
	Single portions container / Vaschetta monoporzioni 360x250x43h	•	•	•
Pastry trays Vassoi pasticceria	Separate / Separati 	Single / Unico 	Separate / Separati 	

		120	170	220
External dimensions (LxDxH) Dimensioni esterne (LxPxH)	H117	1187x1110x1175 mm	1682x1110x1175 mm	2177x1110x1175 mm
	H135	1187x1110x1352 mm	1682x1110x1352 mm	2177x1110x1352 mm
Capacity (gross/net) Capacità (lorda/netta)	H117	685 / 147 lt	1009 / 216 lt	1332 / 285 lt
	H135	824 / 147 lt	1212 / 216 lt	1600 / 285 lt
Net weight Peso netto	H117	320 kg	409 kg	510 kg
	H135	346 kg	434 kg	535 kg
Refrigeration Refrigerazione	Ventilated Ventilata			
Refrigerant Refrigerante	R404A			
Climate class Classe climatica	4 (Plus 1 / Plus 2)			
	7 (Plus)			
Operating conditions Condizioni ambientali	35 °C / 75 %RH (Plus)			
	30 °C / 55 %RH (Plus 1 / Plus 2)			
Cabinet capacity range Temperatura di regolazione	-20/+2 °C			
Product temperature Temperatura prodotto	-16/-14 °C			
Compressor (type) Compressore (tipologia)	1 Hermetic 1 Ermetico		2 Hermetics 2 Ermetici	
Defrost Sbrinamento	Reverse Cycle Inversione di Ciclo			
Power supply Alimentazione	230 V / 1 Ph / 50 Hz		400 V / 3 Ph / 50 Hz	
Electrical input (nominal) Assorbimento elettrico (regime)	1240 W / 6 A		1720 W / 3 A	2700 W / 4,2 A
Electrical input (defrost) Assorbimento elettrico (sbrinamento)	2300 W / 11 A		2950 W / 4,9 A	6300 W / 8,5 A

Technical sheet about models whit condensing unit included with air cooled
Dati tecnici riferiti a modelli con unità a bordo con condensazione ad aria

Setup

Allestimento

5 Lt 360 x 165 x 120 h		12	18	24
5 Lt 360 x 250 x 80 h		8	12	16
5 Lt (trapezoidali) 360 x 185 x 120 h		-	-	-
Ice cream stick container Vaschetta stecchi		8	12	16
Single portion container Vaschetta monoporzioni		8	12	16
Pastry Tray Vassoi pasticceria PLUS - PLUS 1 - PLUS 2		•	•	•

Accessori

Accessories

Grey cone holder Portaconi completo grigio	•
Cone holder complete of toppings container Portaconi completo di vaschette portagranelle	•
Console scoop washer with shower Console lavaporzionatore con doccia	•
Console scoop washer with water tap Console lavaporzionatore con rubinetto	•

120+50	170+50	AE45
1682x1110x1175 mm	2177x1110x1175 mm	1847x1110x1175 mm
1682x1110x1352 mm	2177x1110x1352 mm	1847x1110x1352 mm
1009 / 216 lt	1332 / 285 lt	901 / 193 lt
1212 / 216 lt	1600 / 285 lt	1082 / 193 lt
409 kg	510 kg	400 kg
434 kg	535 kg	425 kg
Ventilated Ventilata		
R404A		
-	7 (Plus)	4 (Plus 1 / Plus 2)
35 °C / 75 %RH (Plus)		
-	30 °C / 55 %RH (Plus 1 / Plus 2)	
-20/+2 °C differenziabili per zona	-20/+2 °C	
-16/-14 °C differenziabili per zona	-16/-14 °C	
2 Hermetics 2 Ermetici		
Reverse Cycle Inversione di Ciclo		
400 V / 3 Ph / 50 Hz		
1720 W / 3 A	2700 W / 4,2 A	1720 W / 3 A
2950 W / 4,9 A	6300 W / 8,5 A	2950 W / 4,9 A

18 (6+12)	24 (6+18)	13
12 (4+8)	16 (4+12)	9
-	-	14
12 (4+8)	16 (4+12)	9
12 (4+8)	16 (4+12)	9
•	•	•

•	•
•	•
•	-
•	-



*Cioccolato
Stracciatella
Crema
Fondilatte
Nocciola
Caffè
Piscaccia
Bacio
Yogurt
Gianduja
Vaniglia*

*Torrone
Nutella
Pinolata
Zuppa inglese
Cookies
Tiramisù
Liquorizia*

*Fragola
Pesca
Limonc
Melonc
Anguria
Mango
Cocco
Banana
Mela
Ananas
Kiwi*



H117



Single evaporator with double front air out flow. Fixed deflectors.

Singolo evaporatore con doppia mandata d'aria a flusso anteriore. Deflettori fissi.

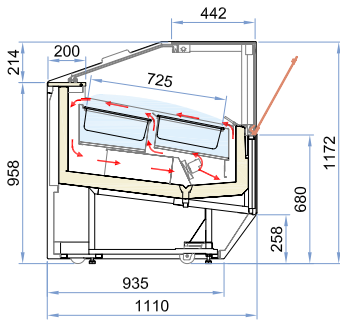

Double evaporator with single air out rear flow. Adjustable deflectors.

Doppio evaporatore con singola mandata d'aria a flusso posteriore. Deflettori regolabili.

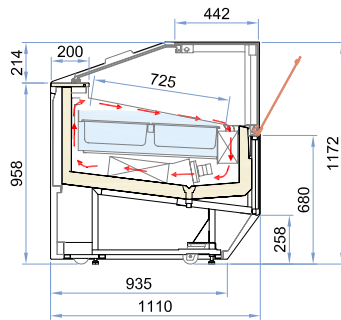

Double evaporator with double air out rear flow. Adjustable deflectors.

Doppio evaporatore con doppia mandata d'aria a flusso posteriore. Deflettori regolabili.

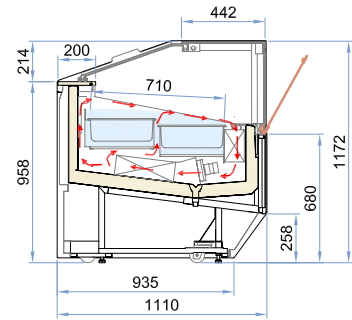

H135



Single evaporator with double front air out flow. Fixed deflectors.

Singolo evaporatore con doppia mandata d'aria a flusso anteriore. Deflettori fissi.

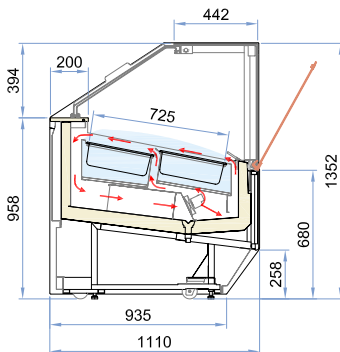

Double evaporator with single air out rear flow. Adjustable deflectors.

Doppio evaporatore con singola mandata d'aria a flusso posteriore. Deflettori regolabili.

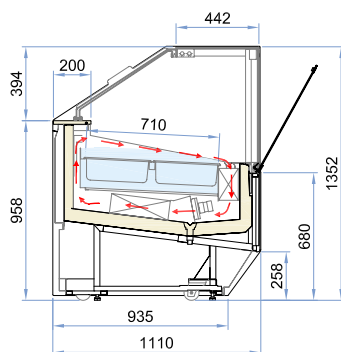

Double evaporator with double air out rear flow. Adjustable deflectors.

Doppio evaporatore con doppia mandata d'aria a flusso posteriore. Deflettori regolabili.

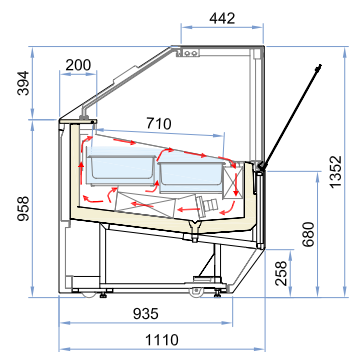

Available colours - Colori disponibili

Front panel (1)
Pannello frontale

- RAL 9003
- RAL 9005
- RAL 7022
- RAL on demand

Standard / Di serie

Front panel (2)
Pannello frontale

- RAL 9003
- RAL 9005
- RAL 7022
- RAL on demand

Standard / Di serie

Side panels (3)
Fianchi laterali

- RAL 9003
- RAL 9005
- RAL 7022
- RAL on demand

Standard / Di serie



PASTRY

SUPERCAPRI

OLI
L
A
TICO
E
FEN
INI

CIOCcolato
STRACCIATELLA
CREMA
FIORDILATTE
NOCCIOLE
CAFFÈ
PISTACCHIO
BAGIO
YOGURT
GIANDUIA
VANIGLIA
TORRONE
NUTELLA
PINOGLATA
MENTA
FRAGOLA
PESCA
LIMONE
MELONE
ANGURIA
KIWI
MANGO
AMARENA
COCO
BANANA
FRUTTI SECCO
MIRTA
ANANAS



Pastry H135

Gelato H135



SUPERCAPRI

H 117 • 135

P 111

L 120 • 170 • 220 • AE45

Pastry

Refrigerated shelves

Mensole refrigerate

Installation

- Plug-in
- Remote (optional)

Configuration

Canalized (optional)

Temperature

+1/+10 °C

Refrigerant

R404A

Refrigeration

Ventilated

Compressor

Hermetic

Defrost

Off cycle

Climate class

3

Upper glass

Heated stratified with switch

Front glass

Heated stratified

Side glasses

Heated double

Opening system

Front glass tilted manually

Rear closing system

- Plexiglass Sliding doors
- Self rolling curtain

Work top

Solid surface White

Lighting

Led 5700 K°

Equipment handling

Swivel casters with brake and height adjustable feet

Installazione

- Plug-in
- Remoto (optional)

Configurazione

Canalizzabile (optional)

Temperatura

+1/+10 °C

Refrigerante

R404A

Refrigerazione

Ventilata

Compressore

Ermetico

Sbrinamento

Fermata compressore

Classe Climatica

3

Vetro superiore

Stratificato riscaldato (disattivabile)

Vetro frontale

Stratificato riscaldato

Vetri laterali

Doppi (Camera) riscaldati

Apertura anteriore

Ribaltabile verso il basso

Chiusura posteriore

- Scorrevoli in Plexiglass
- Tenda manuale autoavvolgente

Piano di servizio

Superficie solida bianca

Illuminazione

Led 5700 K°

Movimentazione

Ruote pivotanti con freno e piedini regolabili in altezza



Front glass
Heated stratified

Vetro frontale
Stratificato riscaldato

Upper glass
Heated stratified
with switch

Vetro superiore
Stratificato riscaldato
(disattivabile)

Side glasses
Heated double glasses

Vetri laterali
Doppi (Camera) riscaldati



		120	170	220
External dimensions (LxDxH) Dimensioni esterne (LxPxH)	H117 H135	1187 x 1110 x 1175 mm 1187 x 1110 x 1352 mm	1682 x 1110 x 1175 mm 1682 x 1110 x 1352 mm	2177 x 1110 x 1175 mm 2177 x 1110 x 1352 mm
Capacity (gross/net) Capacità (lorda/netta)	H117 H135	685 / 267 lt 824 / 267 lt	1009 / 393 lt 1212 / 393 lt	1332 / 518 lt 1600 / 518 lt
Net weight Peso netto	H117 H135	300 kg 325 kg	375 kg 410 kg	470 kg 510 kg
Refrigeration Refrigerazione		Ventilated Ventilata		
Refrigerant Refrigerante		R404A		
Climate class Classe climatica		3		
Operating conditions Condizioni ambientali		25 °C / 60 %RH		
Product temperature Temperatura prodotto		+1/+10 °C		
Compressor (type) Compressore (tipologia)		1 Hermetic 1 Ermetico		
Defrost Sbrinamento		Off Cycle Fermata compressore		
Power supply Alimentazione		230 V / 1 Ph / 50 Hz		
Electrical input (nominal) Assorbimento elettrico (regime)		1360 W / 7,4 A	1485 W / 8,1 A	1610 W / 8,7 A
Electrical input (defrost) Assorbimento elettrico (sbrinamento)		420 W / 2,3 A	485 W / 2,6 A	450 W / 2,4 A

Technical sheet about models whit condensing unit included with air cooled
Dati tecnici riferiti a modelli con unità a bordo con condensazione ad aria

Setup

Allestimento

Pastry trays
Vassoio pasticceria

•	•	•
---	---	---

Available colours - Colori disponibili

Front panel (1)
Pannello frontale

RAL 9003

RAL 9005

RAL 7022

RAL on demand

Standard / Di serie

Front panel (2)
Pannello frontale

RAL 9003

RAL 9005

RAL 7022

RAL on demand

Standard / Di serie

Side panels (3)
Fianchi laterali

RAL 9003

RAL 9005

RAL 7022

RAL on demand

Standard / Di serie



AE45

1847 x 1110 x 1175 mm

1847 x 1110 x 1352 mm

901 / 193 lt

1082 / 193 lt

400 kg

425 kg

Ventilated
Ventilata

R404A

3

25 °C / 60 %RH

+1/+10 °C

1 Hermetic
1 Ermetico**Off Cycle**
Fermata compressore

230 V / 1 Ph / 50 Hz

1485 W / 8,1 A

485 W / 2,6 A

•

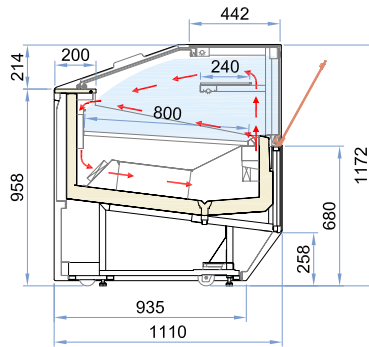
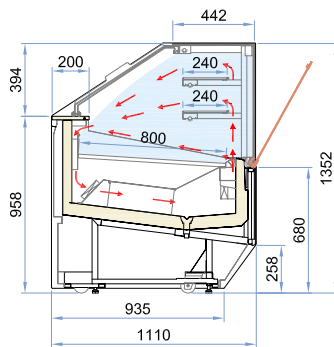
H117**H135**

CANNOLI
CORNETTI
BISCOTTI
BABBA
DIPLOMATICO
BIGNE
KRAPPEN
PASTICCINI

CIOCOLATO
STRACCIATELLA
CREMA
FIORDILATTE
NOCCHIOIA
CAFFÈ
COSTACCHIO
FAGIOL
YOGURT
PANCETTA
MOPRONE
MATELLA
PINOIATA
MENTA

FRAGOLA
PESCA
LIMONE
MELONE
ANGURIA
KIWI
MANGO
AMARENA
COCO
BANANA
FRUTTI DI BOSCO
MENA
ANANAS



Pastry H135
Gelato H135





ISA nasce in Umbria, nel cuore di quell'Italia rinomata in tutto il mondo per la sua eccellenza artigiana, industriale e creativa. Con quattro stabilimenti e la presenza in oltre 100 mercati globali ISA è uno dei player al mondo più importanti del mercato dell'arredamento per locali pubblici, delle vetrine e degli armadi refrigerati per gelateria e pasticceria e dell'arredamento professionale.

ISA was established in Umbria, in the heart of Italy, a nation that is famed all over the world for its artisan, industrial and creative excellence. With four sites and the presence in over 100 global markets, ISA is one of the most important players on furniture market for public places, ice cream display cabinets, pastry display cases and professional furniture.

ISA nait en Ombrie, au milieu de cette partie-là d'Italie célèbre dans tout le monde pour son excellence artisanale, industrielle et créative. Avec quatre usines et en étant sur plus de 100 marchés globaux, ISA est un des joueurs les plus importants sur le marché international de l'ameublement pour locaux publiques, de vitrines et d'armoires d'exposition réfrigérées pour glacerie et pâtisserie et de l'ameublement professionnel.

ISA wurde in Umbrien gegründet, im Herzen Italiens, die in der ganzen Welt für ihre handgefertigte, industrielle und kreative Vorzüglichkeit berühmt ist. Mit vier Werkanlagen und dank der Anwesenheit in mehr als 100 ISA Global Märkten, ist ISA einer der wichtigsten Player der weltweiten Möbelmarkt für Lokale, Vitrinen und Kühlschränke für Eisdiele und Konditorei und professionelle Einrichtung.

ISA nace en Umbria, en el corazón de una Italia de renombre en todo el mundo por su artesanía, industria y creatividad excelentes. Con cuatro establecimientos y presente en más de 100 mercados globales, ISA es uno de los principales protagonistas mundiales del mercado del mobiliario profesional y de locales públicos así como de los expositores y refrigeradores para heladería y pastelería.



ISO 14064

La ISA S.p.A. nell'ambito del continuo miglioramento del prodotto, si riserva il diritto di modificare in qualsiasi momento, senza preavviso, le caratteristiche tecniche ed estetiche dei propri modelli.

In the interest of continual product improvements, ISA S.p.A. reserves the right to make changes in technical specifications and accessories at any moment and without prior notice.



ISA S.p.A.

via Madonna di Campagna 123
06083 Bastia Umbra (PG)
Italy

T. +39 075 801 71

F. +39 075 800 09 00

E. customerservice@isaitaly.com

www.isaitaly.com

